



Signalisation ON AIR

Visual display



DESCRIPTION

Le RGL500 est un panneau de visualisation "ON AIR" à leds.

Les leds garantissent une durée de vie illimitée par rapport à un éclairage traditionnel.

Alimentation par l'interface ASM120D ou par l'alimentation rackable PCS212. Dans le dernier cas, le pilotage sera effectué par une boucle appliquée directement sur le RGL500

The RGL500 is an ON AIR display unit with leds. They guarantee indefinite useful life compared with a traditional lighting.

Power supply by ASM120D interface or by PCS212 power supply on rack.

In the last case, the control will be executed by a loop directly applied on the RGL500.

UTILISATION / USES

Example 1 :

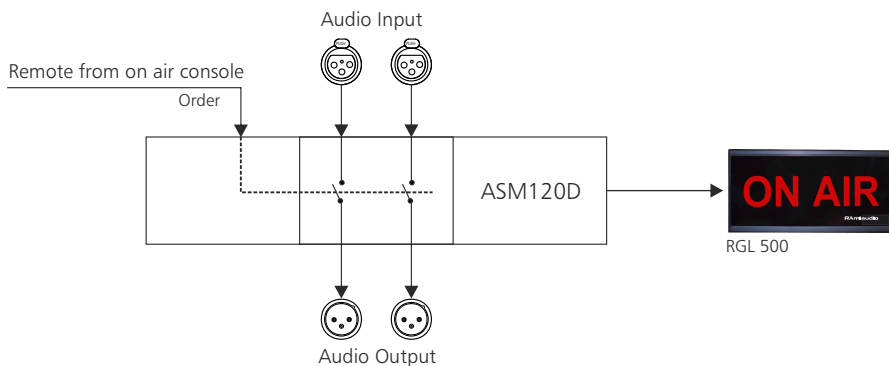

Example 2:

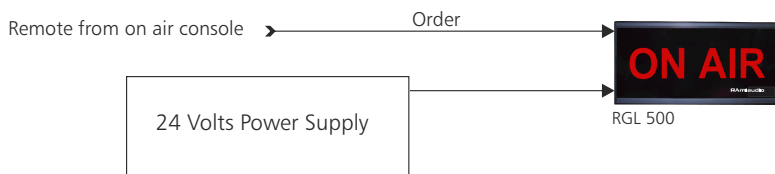

SYNOPTIQUE / BLOCK DIAGRAM

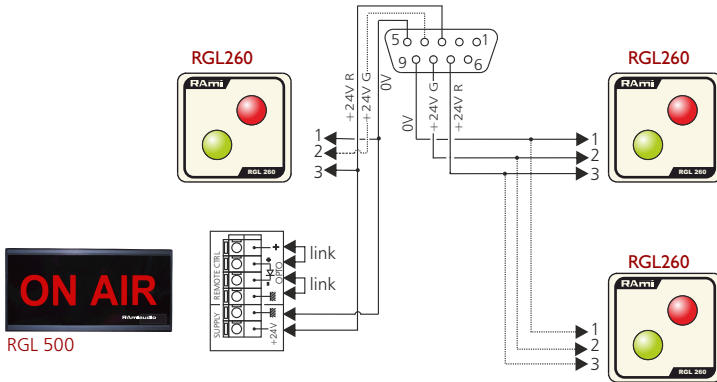
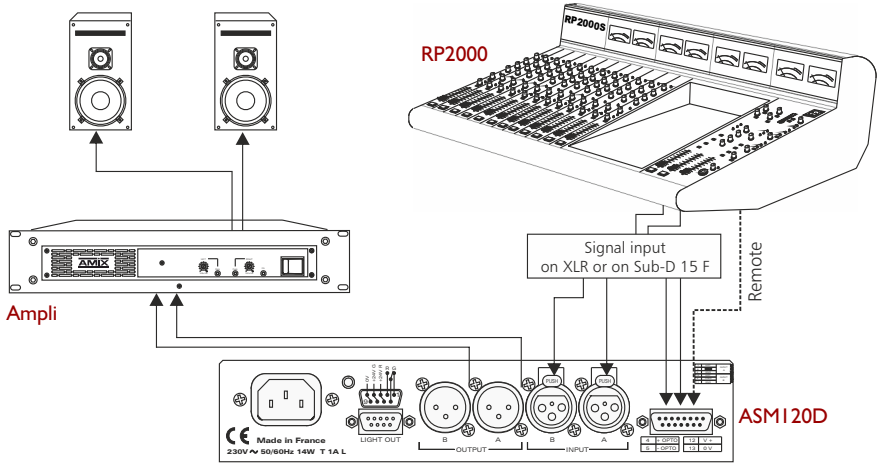

Câblage connecteurs / Wiring

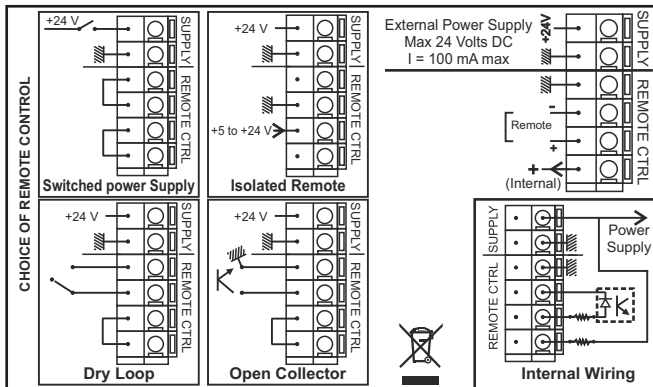

RAmi

7 Rue Raoul Follereau
77600 BUSSY SAINT GEORGES - FRANCE

Tél. : 33 (0)1 64 66 20 20- Fax : 33 (0)1 64 66 20 30

E-mail : rami@ramiaudio.com

www.ramiaudio.com